



HTRH SERIES

**High Temperature, Relative Humidity/
Temperature Probe Transmitter**

**Publication Date: February 2009
Document Number: HTRH-900-01 Rev D**

NOTE: This User's Manual was as current as possible when this product was manufactured. However, products are constantly being updated and improved. To ensure you have the latest documentation refer to www.tegam.com.

TABLE OF CONTENTS

A. GENERAL DESCRIPTION	4
B. UNPACKING	4
C. THEORY OF OPERATION	5
D. TERMINAL CONNECTIONS AND TRIM POTS	6
E. WIRING EXAMPLES	7
F. MOUNTING.....	8
G. RH AND TEMPERATURE CALCULATIONS.....	9
H. RH CALIBRATION	10
I. TEMPERATURE CALIBRATION.....	10
J. MAINTENANCE.....	11
K. SPECIFICATIONS.....	12
WARRANTY	13
STATEMENT OF CALIBRATION.....	13

A. GENERAL DESCRIPTION

The stainless steel probe provides relative humidity as well as temperature outputs. A thin film polymer capacitor senses relative humidity, while temperature is monitored by a 1000 Ohm platinum RTD. The sensors are protected by a stainless steel filter cap easily removed for cleaning. The probe is connected to an electronics enclosure with a 40 inch (1m) Teflon cable. The enclosure contains the calibration trimmers, signal and power connections via two terminal blocks. The probe is available in two configurations, as a 2.5" (64 mm) probe with a wall mounting clip, and as an 8.5" (216 mm) probe with an adjustable duct flange.

B. UNPACKING

Verify that the following parts have been received.

1. Remove probe with cable and electronics enclosure.
2. Instruction manual.
3. Wall mounting clip [for 2.5" (64 mm) probe].
4. 2 piece duct flange, with o-ring, (3) screws, and a gasket.
[for 8.5" (216 mm) probe]

C. THEORY OF OPERATION

A 4 to 20 milliamp loop is a series current loop in which a transmitter will vary the current flow depending upon the parameter being measured (Relative Humidity or Temperature). Advantages of a current output over a voltage output is that is less susceptible to noise interference and allows the connection of more than one meter or recorder to the loop as long as the maximum resistance is not exceeded.

The typical current loop will consist of a power supply, transmitter, and a meter to measure the current flow. The loop resistance is the sum of the impedance of the meter(s) and the lead wire. The maximum allowable loop impedance of the probe is found by the Formula:

$$R_{max} = (\text{power supply voltage} - 7 \text{ volts}) / .02 \text{ amps}$$

Example: when using a 24 VDC power supply:

$$R_{max} = (24 - 7) / .02 = 850 \text{ ohms (for total wire length to and from the transmitter).}$$

<u>AWG WIRE SIZE</u>	<u>RESISTANCE PER 1000 FEET</u>
24	25 OHMS
22	15 OHMS
20	10 OHMS
18	6 OHMS
16	4 OHMS

If the meter or recorder being used accepts only voltage, convert the current to voltage by installing a 250 ohm resistor across the input terminals of the recorder to obtain a 1 to 5 volts input.

D. TERMINAL CONNECTIONS AND TRIM POTS

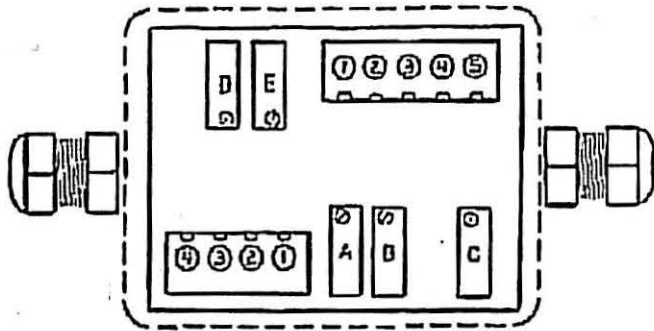

TRIMPOTS TYPE

- A. RH GAIN
- B. RH ZERO
- C. RH OFFSET
- D. TEMP GAIN
- E. TEMP ZERO

PROBE TERMINALS

1
2
3
4
5

CABLE WIRE

BLACK
WHITE
GREEN
RED
SHEILD

TYPE

RTD
RTD
RH
RH
—

OUTPUT TERMINALS

1
2
3
4

TYPE

-RH
+RH
-TEMP
+TEMP

E. WIRING EXAMPLES

TYPICAL CURRENT HOOKUP

Wires R1 and R2 can be combined into one single wire with a jumper at pins (4) and (2). This will result in 3 wires instead of 4.

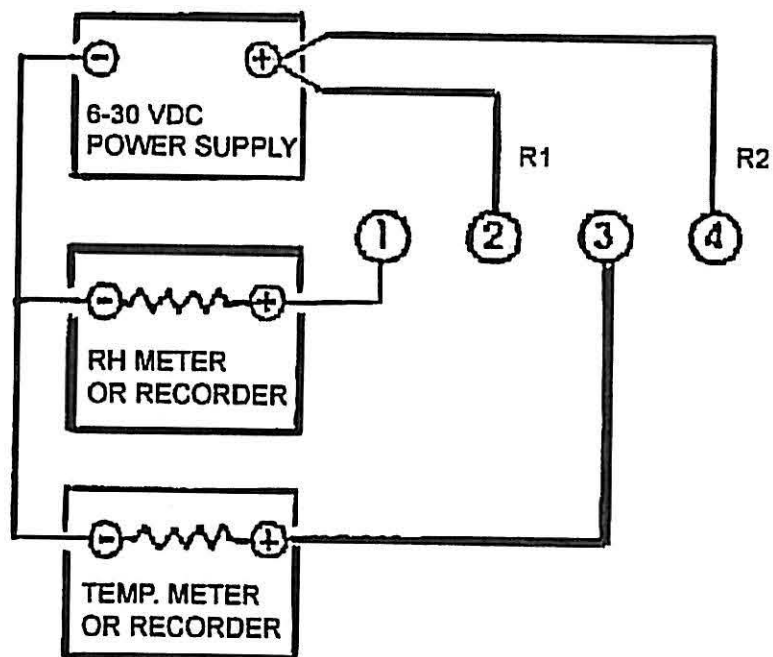

F. MOUNTING

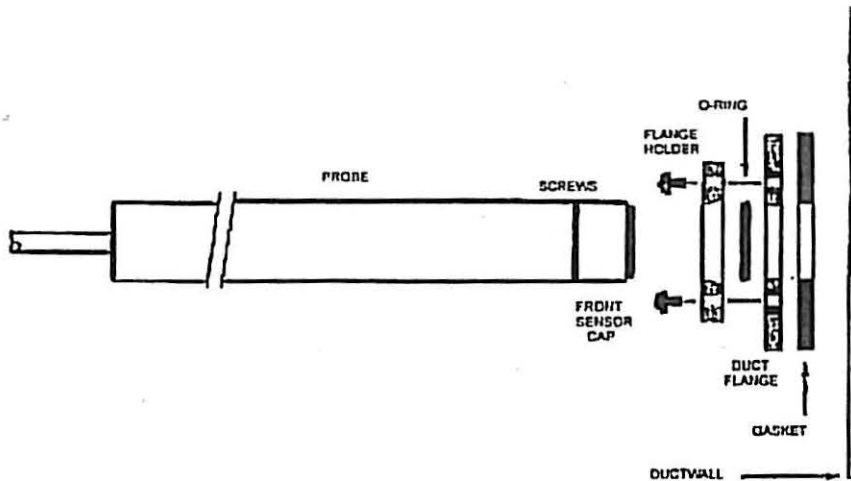

A. DUCT MOUNTING STEPS

1. Slide flange holder onto probe with countersink hole facing front of probe as shown.
2. Position o-ring on probe at desired position (for depth into duct).
3. Slide duct flange onto probe as shown.
4. Fasten with (3) 6/32 screws and tighten evenly until secure.
5. Position gasket between duct flange and duct wall and fasten assembly to duct with (4) #6 sheet metal screws (not included).
6. Loosening the 6/32 screws allows for repositioning or removal of the probe without having to remove the duct flange from the wall.

The duct wall requires a $11/16''$ (.684" or 17.5 mm) hole for probe, with (4) mounting holes (for #6 sheet metal screws) evenly spaced on a 2.0" (51 mm) circle. Use duct flange as template.

B. WALL MOUNTING

1. Fasten metal clip to wall.
2. Snap probe into clip.

G. RH AND TEMPERATURE CALCULATIONS

1. Maximum current loop impedance for RH or temperature.

$$R_{max} = (V \text{ supply} - 7 \text{ volts}) / .02 \text{ amps}$$

2. RH current output (i = current output in milliamperes)

3. Temperature current output.

$$oC = (i-4) \times 220/16 - 40 \quad iC = (oC + 40) \times (16/220) + 4$$

$$oF = (i-4) \times (396/16) - 40 \quad iF = (oF + 40) \times (16/396) + 4$$

The upper limit of the humidity measurement range decreases based on temperature. The humidity measurement limit decreases as follows:

2.20% per °C from 95 to 120°C (1.11% per °F from 203 to 248°F)

1.00% per °C from 120 to 140°C (0.56% per °F from 248 to 284°F)

0.50% per °C from 140 to 160°C (0.28% per °F from 284 to 320°F)

0.25% per °C from 160 to 180°C (0.14% per °F from 320 to 356°F)

For example, at 120°C the upper humidity limit decreases to about 45% $((120-95)(2.20\%) = 55\% \text{ decrease which is } 45\%)$, at 180°C it is reduced to about 10%.

To calculate the RH accuracy, we'll use the accuracy specs given in the specifications section:

+/-2%RH at 25°C and -40° to 150°C at 0.05 % RH/°C.

To clarify lets take an example,

RH accuracy at 120°C,

$$= +/- (2\% + (120-25)0.05\%) = +/- (2\% + 4.75\%)$$

$$= +/-6.75\%$$

So the accuracy at 120°C is +/-6.75% and the upper humidity measurement limit is 45% RH.

H. RH CALIBRATION

Refer to Section D for the location of trim pots A and B.

Note: The TEGAM RH-CAL Relative Humidity Calibration Kit is recommended for providing the “low” and “high” RH environments for this procedure. The salt solutions in this kit are prepared according to ASTM standard E104-85 to provide 11.3% and 75.3% relative humidity environments. The containers provided in the kit are designed to fit with these instruments.

1. Turn the span (trim pot A) all the way up (clockwise).
2. Turn the zero (trim pot B) all the way down (counter-clockwise).
3. Place the sensor in the low (11.3%) RH environment. Allow at least one hour for stabilization or until the output stops changing.
4. Verify the output is 4 ± 0.02 mA. If it is not, return the unit to TEGAM for evaluation and repair.
5. Adjust the zero (trim pot B) to the point where it just starts to cause a change in the output.
6. Place the sensor in the high (75.3%) RH environment. Allow at least one hour for stabilization or until the output stops changing.
7. Adjust the span (trim pot A) so the output is equivalent to the difference between low and high RH environments. Example: $75.3\% - 11.3\% = 64\%$ which is equivalent to 14.24 mA.
8. Adjust the sensor in the low RH environment and allow at least one hour for stabilization or until the output stops changing. Verify the output is equivalent to the low RH environment. Example: 11.3% is equivalent to 5.81 mA.

I. TEMPERATURE CALIBRATION

Temperature is factory calibrated only, and does not require any further calibrations.

J. MAINTENANCE

If the probe is operated in a dusty environment, the protective sensor filter, if clogged, may be removed for cleaning. Unscrew filter and gently blow compressed air through screen. If necessary, use a soft brush to remove lint from sensors.

If the sensors are subjected to 100% condensation, they must be dried to obtain correct readings. There is no permanent calibration shift, nor is recalibration necessary if 100% condensation occurs.

The instrument should not be exposed to high concentrations of ammonia or alcohol vapors. However, any environment that is breathable under normal HVAC applications should not affect the sensors. To maintain original specifications, it is generally recommended that the RH sensor be recalibrated on an annual basis depending upon operating conditions. The temperature sensor does not require calibration.

K. SPECIFICATIONS

1. Relative Humidity: Thin film polymer capacitor.
Input Voltage Range: 7 to 30 VDC (polarity protected).
Range, Accuracy: 3% RH to 95% RH (@-40 to 95°C)*, ±2%RH at 25°C
Typical Temp. Characteristics: -40°C to 150°C at .05%RH/°C
Output: 4 to 20 ma. For 0%RH to 100%RH.
Time Constant: Under 30 seconds, 90% response at 25°C in 1M/sec air.
* See RH and Temperature Calculations section for full range.
2. Temperature: Thin film 1000 ohm platinum RTD.
Input Voltage Range: 7 to 30 VDC (polarity protected).
Range, Accuracy: -40°C to 180°C (-40°F to 356°F), ±0.5°C (±1°F)
Output: 4 to 20 ma. For -40°C to 180°C (-40°F to 356°F)
Time Constant: Under 4 seconds, 60% response in 1m/sec air.
3. Mechanical
Standard Probe Stainless steel, 2.5" (64 mm) x .625" (16 mm) diameter. 40" (1m) Teflon cable, metal wall mounting clip.
Duct Probe: Stainless steel, 8.5" (216 mm) x .625" (16 mm) diameter. 40" (1m) Teflon cable.

Duct Flange: 2.75" (70mm) dia., duct hole 1 1/16 (.684", 17.5mm) dia. With 4 mounting holes .156(4mm) diameter (for #6 sheet metal screws), on 2.00" (51mm)circle.
Electronics: Operating temp. -20°C to 70°C(-4°F to 158°F)
ABS housing 4.72" (120mm) x 3.14" (80 mm) x 2.16" (55 mm) H meets NEMA 1,2,3,4,4X,5,12 and 13 specifications.
Connectors: Liquid-tight with neoprene gland for .09" to .265" diameter cable.
4-pin plug in screw terminal block for output connections.
5-pin screw terminal block for cable wire input connections. Accepts #14 to #22 AWG wires.

Weight: 2.5" (64 mm) probe with housing
14 oz. (397 grams).
8.5" (216 mm) probe with housing and flange
20oz. (567 grams).

WARRANTY

TEGAM, Inc., warrants this product to be free from defects in material and workmanship for a period of one year from date of shipment. During the warranty period, we will, at our option, either repair or replace any product that proves to be defective.

To exercise this warranty, write or call TEGAM, Inc. in Geneva, Ohio. You will be given prompt assistance and return instructions. Send the instrument, transportation prepaid, to the indicated service facility. Repairs will be made and the instrument returned, transportation prepaid. Repaired products are warranted for the balance of the original warranty period, or at least 90 days.

LIMITATION OF WARRANTY

This warranty does not apply to defects resulting from unauthorized modification or misuse of any product or part. This warranty also does not apply to fuses, batteries, or damage from battery leakage.

This warranty is in lieu of all other warranties, expressed or implied, including any implied warranty of merchantability or fitness for a particular use. TEGAM, Inc. shall not be liable for any indirect, special or consequential damages.

STATEMENT OF CALIBRATION

This instrument has been inspected and tested in accordance with specifications published by TEGAM, Inc.

The accuracy and calibration of this instrument are traceable to the National Bureau of Standards through equipment which is calibrated at planned intervals by comparison to certified standards maintained in the Laboratories of TEGAM, Inc.



10 TEGAM WAY · GENEVA, OHIO 44041
PHONE 440-466-6100 · FAX 440-466-6110
www.tegam.com